



## Pump troubleshooting—river pumps and bore pumps

Problems with pumping equipment on the farm are not only an inconvenience, but can also contribute to loss of production.

An efficient farming operation depends upon trouble-free pumping. By keeping pumping equipment in good working order, savings in time and energy costs can be made.

This fact sheet deals with the problems of lineshaft pumps associated with bores and high lift river applications. It outlines pumping malfunctions with probable causes and procedures for checking and correcting possible faults.

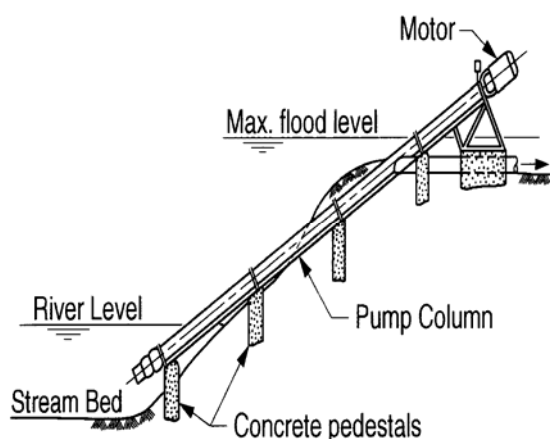

Most pump troubles can be rectified on the farm by the farmer or manager. However, at times, there will be problems or failures which you may not be able to fix. If you cannot identify the problem within this fact sheet, you should consult your supplier or the pump manufacturer.

### Pump shaft hard to turn

- Head nut not properly adjusted
- Sand jamming impellers
- Rubber bearings dry (only need pre-lubrication)
- Rubber bearing swelled due to action of water
- Head bolted down not square to column
- Line shaft bent

- Shaft couplings not fully tightened, and pulled up after first start, jamming the turbine
- Column couplings not fully tightened
- Gland too tight
- Manufacturing faults such as misalignment in turbine, column or thrust assembly
- Bore casing not straight (bending pump)
- Some object dropped inside pump.

### Pump will not start

- Motor wired for reverse rotation
- Motor wired in "star" instead of "delta"
- One or more fuses blown
- Starter tapping provides insufficient torque
- Supply fault
- Starter defective
- Motor defective
- Any faults listed under 'Pump shaft hard to turn'.

### Pump will not deliver water

- Pump running in reverse
- Shaft coupling disconnected
- Shaft broken
- Speed too low
- Total lift too high
- Water level below pump intake
- Intake blocked
- Discharge valve closed
- Water by-passing due to holed column
- Impeller loose on shaft
- Turbine wrongly specified for required lift
- Turbine air-locked due to starved suction
- Water entry to bore blocked.



### Pump will not deliver sufficient water

- Insufficient flow into bore
- Draw-down more than estimated
- Total lift too high
- Speed too low
- Gas in water
- Aeration due to "cascading" water
- Water too hot
- Inlet partially blocked
- Leaks in column or pipe line
- Valve partially closed
- Pump damaged by sand
- Water entry to bore restricted
- Method of flow measurement defective.

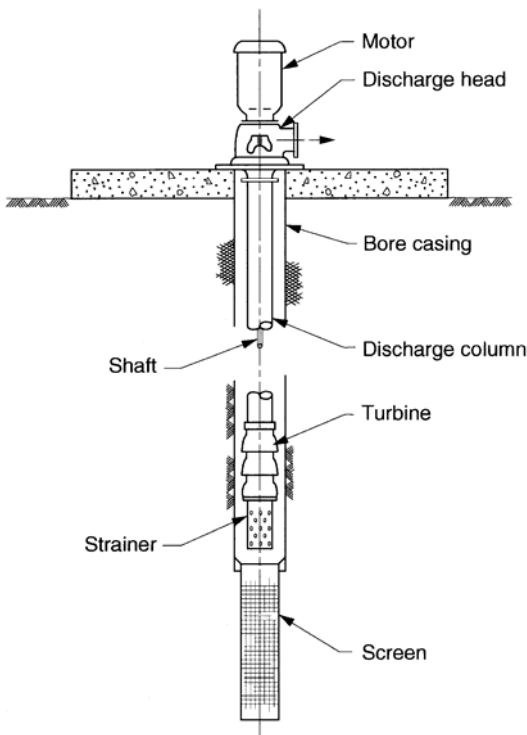

### Pump takes too much power

- All faults listed under 'Pump shaft hard to turn'
- Impellers rubbing under working conditions due to incorrect head nut setting
- Hot water causing differential expansion and resulting in impeller rubbing
- Excessive stretch in long shaft causing impeller rubbing

- Speed too high
- Discharge pressure too high
- Motor wired in "star" instead of "delta"
- Electric supply fault - low voltage or phase failure
- Motor fault
- Vibration resulting from any fault under 'Pump shaft hard to turn'
- Fault in method of measuring power.

### Pump vibrates

- Bearings worn excessively
- Bent line shaft
- Motor out of balance
- Thrust parts out of balance or faulty
- Drive coupling misaligned
- Drive shaft damaged or out of balance
- Engine foundation not adequate
- Pump sucking air
- Vibration resulting from any fault under 'Pump shaft hard to turn'
- Shaft running at a critical speed.

### Excessive wear

- Sand in water
- Bent line shaft
- Bore not straight
- Damage due to corrosion
- Damage due to misalignment and fault in manufacture
- Damage due to vibration
- Incorrect lubrication.

### Excessive noise

- All faults listed above
- Faulty ball bearing in motor or thrust bearing
- Maladjustment of gearbox
- Incorrect lubrication.



## Further information

Should you require assistance or advice on pumps or pumping generally, please contact your local pump manufacturer or retailer.

Fact sheets on water and other topics are available from Natural Resources and Water (NRW) offices and service centres or can be downloaded at [www.nrw.qld.gov.au/factsheets](http://www.nrw.qld.gov.au/factsheets).

*March 2006*

*W28*

*For further information phone 13 13 04*