

Energy efficient home design

GUIDELINES

How an energy efficient home
can help you live
in comfort and save money

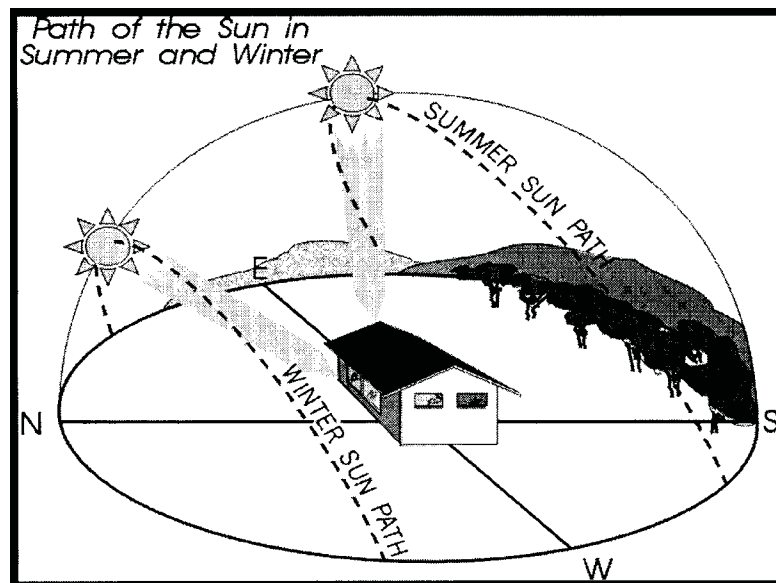

An energy efficient home is designed to provide shade and allow cooling breezes to enter in summer, while taking advantage of the sun's warmth in winter.

In climate areas where air conditioning and heating are necessary, energy efficient house design can greatly reduce cooling and heating costs.

LOCATION

- Energy efficient house design is influenced by climate. Different climatic regions require different approaches to design.
- House design that does not factor in climate conditions will be uncomfortable for most times of the year.
- Queensland has a variety of climate types which can be generally grouped into four distinct climatic regions that influence the design of houses. For example, in northern Queensland, the midday sun in summer will shine onto south facing walls, whereas in southern Queensland the sun will shine onto the north facing wall.
- The optimal orientation, size and shading of windows, the amount and type of insulation and internal design may all need to be varied according to the climatic region in which your home is located.

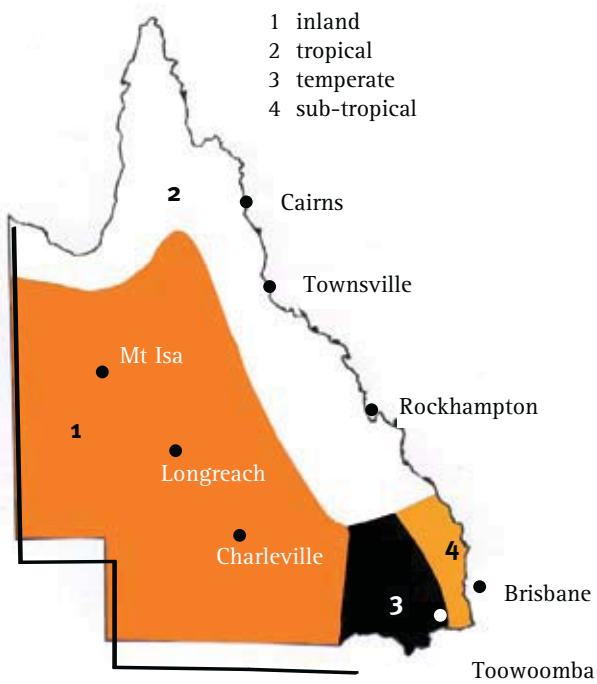

Figure 1a - Map of Queensland's four climatic regions for house design

- The four regions shown in Figure 1a are generally characterised as shown in Figure 1b.

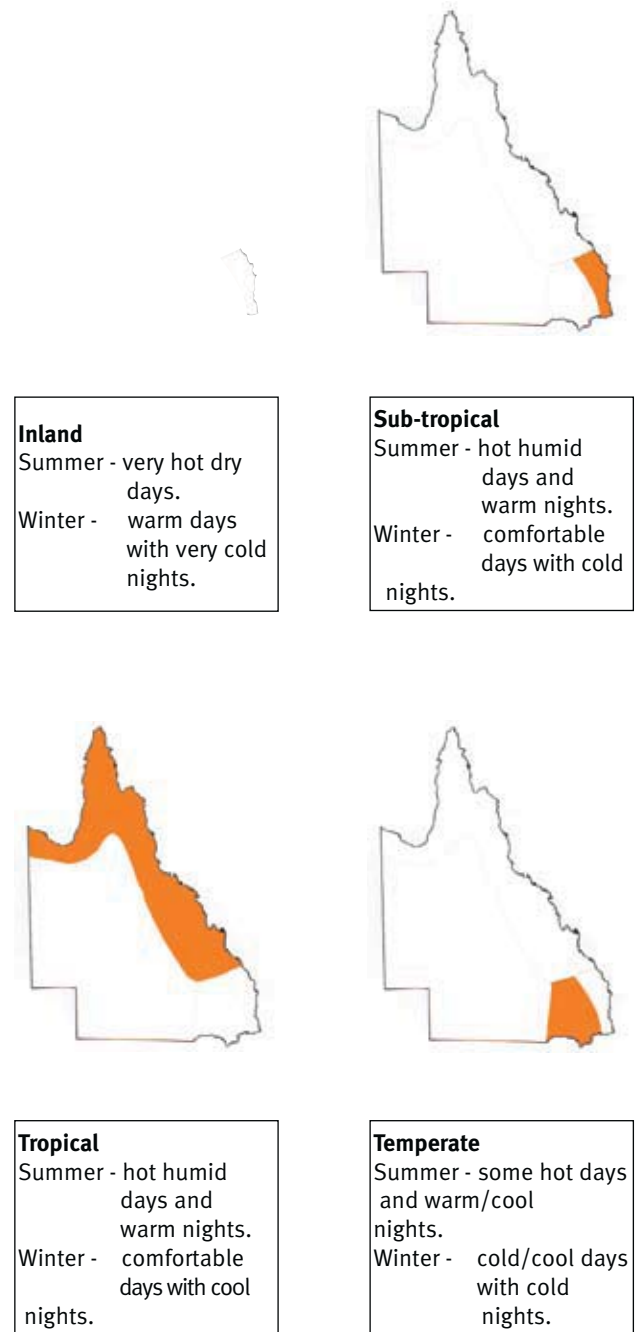

Figure 1b - Characteristics of climatic regions

- The house site can also be influenced by local conditions and may vary from the general regions indicated on the map in Figure 1.

ORIENTATION

- The orientation of the walls and windows effects the amount of heat entering a home.

- North facing windows are easy to shade in summer. They still allow solar heating in winter. East and west facing windows are difficult to shade with eaves in summer.
- The general rule for all climatic regions is to orient the house so the main wall and window areas face north. This minimises solar heating in summer and provides scope for solar heating in winter.

INTERNAL PLANNING

- Locate living and outdoor areas to the north or east. In summer these areas will be cool and generally receive cool afternoon breezes. In winter, they will be warm and sunny.
- Create zones by grouping rooms of similar use together. For example, rooms that use hot water should be located together to allow for more efficient use of your hot water system.

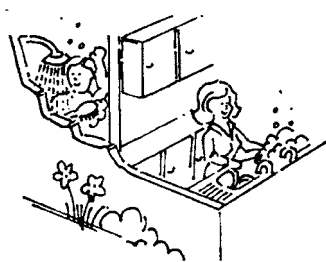

- Areas which are heated or cooled should be able to be closed off from the rest of the house.

WINDOW SIZE AND PLACEMENT

- Carefully consider the size, type and placement of windows. This will be influenced by climate, views, building codes and shading by trees, terrain and/or other buildings.

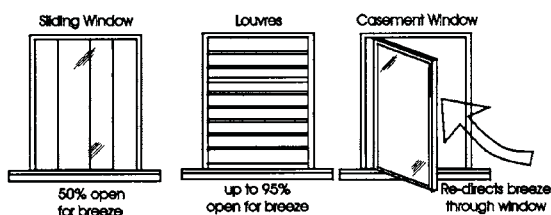

Figure 2 - Types of windows with ventilation aspects

- A wise selection and placement of windows will ensure effective ventilation and help you to keep your house cool in summer and warm in winter.
- Windows such as louvres and casements that open fully or redirect breezes into the home are beneficial in humid climates.

WINDOW PROTECTION

- The most effective way to reduce the amount of heat entering windows in summer is to stop direct sunlight from striking the windows. This can be done by using external shading.
- The sun takes different paths during summer and winter. Shading north and south facing windows in summer can be easily achieved by using the correct width eaves/verandahs for the climatic region in which you are building.

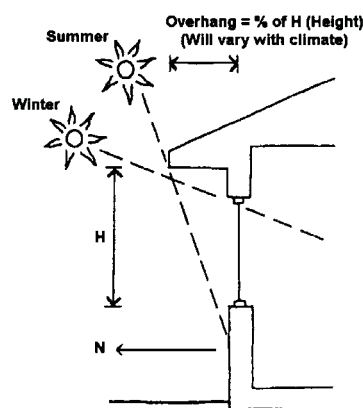

Figure 3 - Determining width of eaves

- Figure 3 above provides a general guide for the correct width of eaves. In south-east Queensland, the width of eaves should be half the height of the tallest windows.
- Areas north of the Tropic of Capricorn also require horizontal shading of southern windows to provide adequate protection from the summer sun.
- Pergolas, verandahs, trees, vines and external blinds all provide shading. Check that they don't obstruct cooling breezes

- In winter reduce heat loss by using close fitting curtains, blinds and pelmets to trap the heat between them and the glass.
- In cold winter areas consider double glazing for all windows.

INSULATION

- Installing insulation can be the most effective way to improve your home's comfort level throughout the year.
- When a home is air conditioned or heated, insulation reduces the amount of energy needed to maintain comfort.
- Insulation reduces the required size of cooling or heating units thus reducing their initial purchase cost. It can also save money on operating costs.
- Insulation may not be effective in houses with large areas of unshaded windows, particularly if the house is not well ventilated.

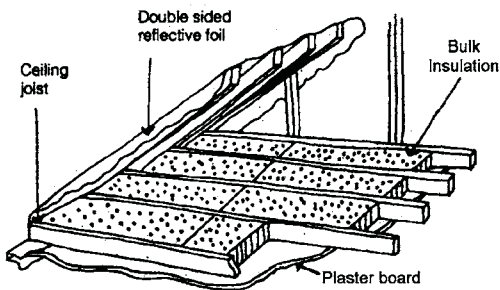

Figure 4 - Insulation installed under roof and in ceiling

- Ceiling insulation should generally have a minimum “R” rating of 2.5 and walls should have R 1.0 to 1.5. For details, see our ‘Guide to Home Insulation’.

BUILDING MATERIALS

- Construction materials such as concrete and brick can absorb and hold large amounts of heat. This heat is then released when the air becomes cooler. These materials are most effective when insulated from the outside.
- In temperate climates, tiled concrete floors and internal masonry (cavity brick, concrete block, reverse brick veneer) walls assist in moderating temperatures inside the home.
- Carpeting a concrete floor will greatly reduce its effectiveness in storing and releasing heat.
- In hot, humid climates, heavy construction materials provide little additional benefit and can be a disadvantage if not completely protected from the sun. Lighter weight construction such as brick veneer or timber/fibre-board-clad construction may be a better option.
- In areas of western Queensland and where there is a cool breeze at night, a combination of heavyweight construction for daytime living areas and lighter weight construction for the bedroom areas is best.

VENTILATION AND INFILTRATION

- Internal layout of rooms, doorways and windows should be considered when planning for good cross ventilation. This allows unhindered flow of natural breezes to provide a cooling effect in hot, humid climates.
- Open plan style and vented high ceilings with ceiling fans are ideal for tropical climates.
- Reducing unwanted draughts by sealing air leaks reduces winter heating requirements and prevents hot, dry and dusty air from entering during summer.
- Any gaps around doors and windows can be sealed with weather stripping. Likewise, caulk any gaps in the house construction such as along skirtings, cornices and other internal lining joints.

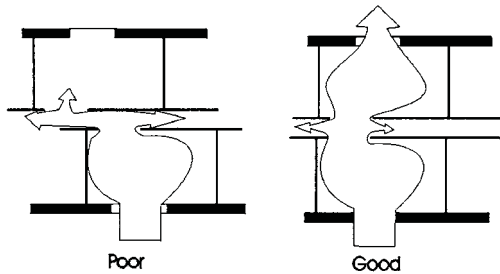

Figure 5 - Cross Ventilation

- Most old “Queenslander” style homes with timber VJ walls are notorious for infiltration and are best suited for humid tropical areas.

LANDSCAPING

- Moderate the temperature inside your home by carefully selecting and placing plants and trees to shade the walls and windows.

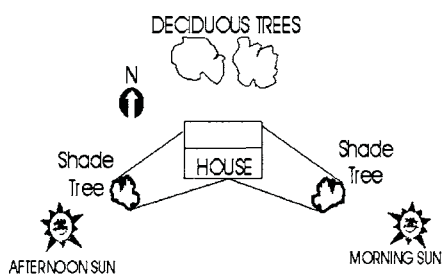

Figure 6 - Shading with trees

- Tall cone-shaped trees to the southwest and southeast are useful to reduce summer heat.
- Protect your house from cold winter winds by planting a windbreak of trees.
- Rows of trees can also be used to redirect cooling summer breezes through your home.

- Deciduous trees to the north provide shade in summer and allow sunlight to enter in winter.

WATER HEATING

- Water heating accounts for the largest use of energy in most Queensland households.

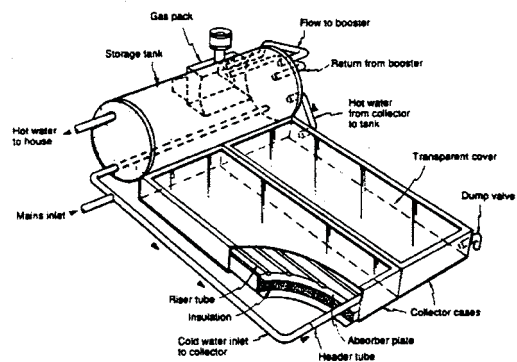

Figure 7 - A two panel solar hot water system

- A solar hot water system can reduce your energy consumption by around 30% and save up to 80% on water heating bills.
- Using low flow shower roses, water efficient appliances and insulating hot water pipes substantially reduces water and energy use.

LIGHTING

- Devoting some time to the layout and type of light fittings when designing your home will improve light quality and lower your energy costs.
- Ensure light levels are appropriate for each area. Diffused lighting is good for general lighting purposes as it provides a better distribution of light with less shadowing and glare.
- Fluorescent lamps give five times the light output and last up to eight times longer than incandescent lamps.

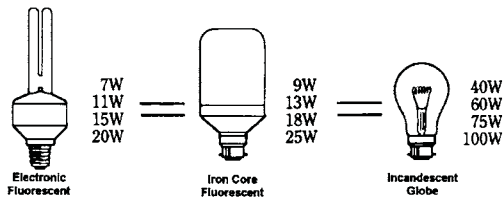

Figure 8 - Incandescent vs fluorescent lights

- Choose light colours in preference to darker colours for ceilings and walls as more light will be reflected around the room.
- Provide separate switches for each lamp to give flexibility in lighting effects.
- The use of 'sensors', time switches, dimmers and two-way switching are effective methods of reducing lighting energy costs.



For more information

call 13 74 68 (13 QGOV)

visit www.derm.qld.gov.au

email sustainable.industries@derm.qld.gov.au

